

YOONAD VALVE (WUXI) CO.,LTD

友耐得阀门(无锡)有限公司

软密封旋塞阀 SOFT SEALED PLUG VALVES
金属硬密封旋塞阀 METAL SEALED PLUG VALVES

口径 Size: ½" - 14" (15 - 350 mm)

压力 Pressure: ASME Class 150 - 900LB

标准 Standard: API 599, API 6D/ISO 14313

材质 Materials: B367 Gr. C-2, A494 CY40,

B752 702C, A890/A995 4A, 904L,

A216 WCB, A351 CF8, A351.CF3M

旋塞阀系列 PLUG VALVE SERIES

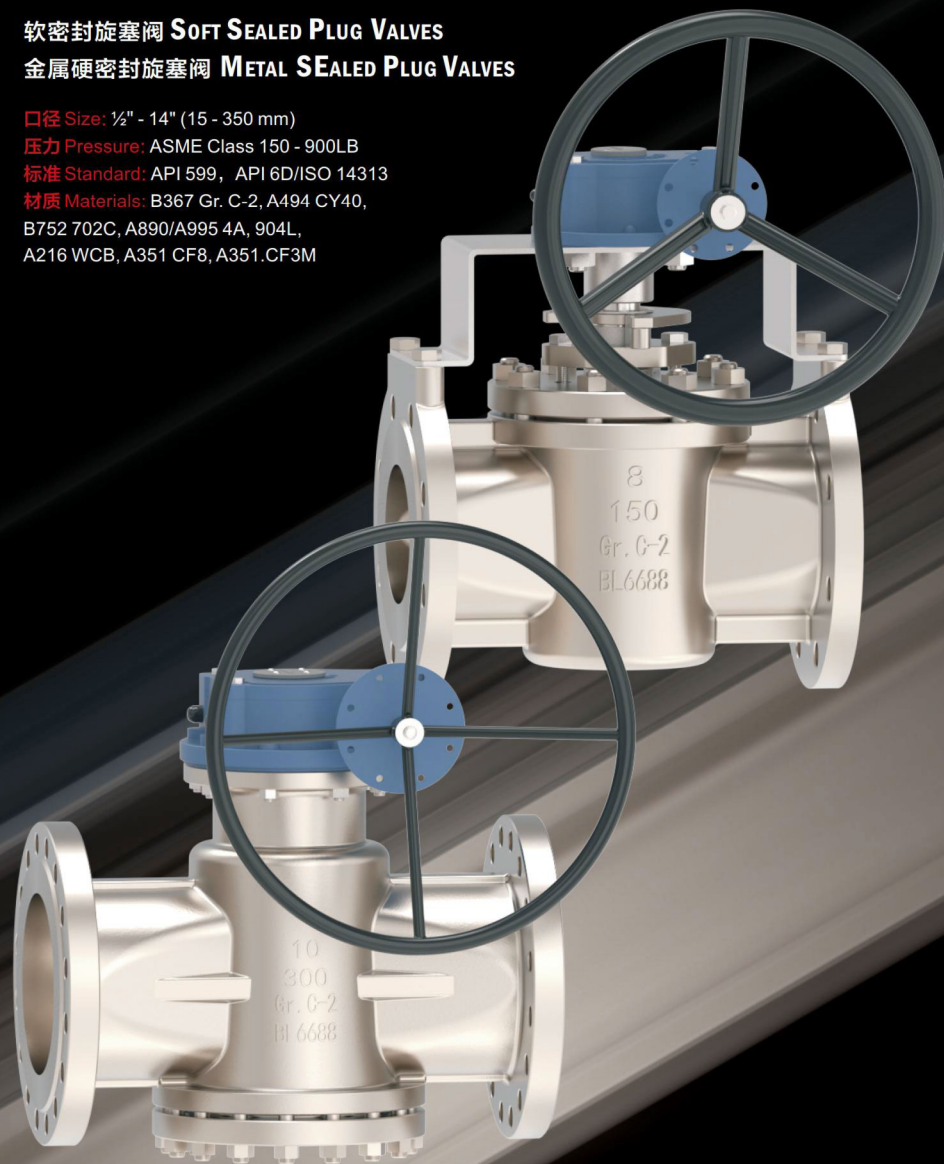

卡套式旋塞阀的特点 FEATURES OF SLEEVE TYPE PLUG VALVE

yoonad®

产品特征 Features Of Product

- 无润滑
- 三重阀杆密封系统
- 无空腔设计
- 360度金属唇设计
- 防静电设计
- 防火安全
- 可更换套筒
- 阀体腔内无死区

- Non-Lubrication
- Threefold Stem Seal System
- Cavity Free Design
- 360 Degrees Metal Lips Design
- Anti Static Design
- Fire Safe
- Replaceable Sleeve
- Zero Dead Space

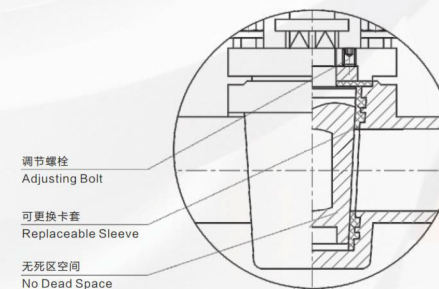

设计特征 Design Features

旋塞阀是一种类似于球阀的四分之一回转阀。阀门关闭系统由锥形塞组成，锥形塞靠在软材料套筒上或靠在阀体上。李朗卡套式旋塞阀适用于公称压力CLASS150-900LBS,工作温度在-29℃到180℃的石油，化工，制药，化肥，电力行业等各种工况的管路上，切断或接通管路介质。李朗旋塞阀产品设计结构合理、密封可靠、性能优良，造型美观。具有以下特点：

A plug valve is a quarter turn valve similar to a ball valve. The valve closing system consists of a conical plug, which is placed against a soft material sleeve or against the valve body. The BOLON sleeve type plug valve is suitable for cutting off or connecting pipeline media in various working conditions such as petroleum, chemical, pharmaceutical, fertilizer, and power industries with a nominal pressure of Class150-900LBS and a working temperature of -29℃ to 180℃. The design structure of BOLON plug valve is reasonable, the sealing is reliable, the performance is excellent, and the appearance is beautiful. It has the following characteristics:

阀体无死区设计 No Dead Cavity Space

该阀门没有空腔的设计，以确保阀体内不会有介质积聚。这种无空腔设计还可以防止粘连。BOLON旋塞阀在流动路径中没有死腔空间，因此浆料等介质不会积聚在阀门中的任何地方。

The valve is not designed with a cavity to ensure that there is no accumulation of medium inside the valve body. This cavity free design can also prevent adhesion. The BOLON plug valve has no dead space in the flow path, so media such as slurry will not accumulate anywhere in the valve.

独特的360度金属唇边设计 Unique 360 Degree Metal lip Design

密封性通过卡套四周的密封面实现。独特的360度金属唇边可以确保固定卡套。其独特的独特的360度金属唇边设计可有效提高阀门性能，延长阀门使用寿命，防止套筒冷流和变形；同时，这种特殊的设计防止了在高温下膨胀的趋势。当阀塞旋转时，分解并去除阀塞外表面的沉积物。金属唇边在旋转时提供自动清洁的作用，适用于粘稠和易结垢的工况。

Sealing is achieved through the sealing surfaces around the sleeve. The unique 360 degree metal lip edge ensures a secure clip. Its unique 360 degree metal lip design can effectively improve valve performance, extend valve service life, and prevent sleeve cold flow and deformation; Meanwhile, this special design prevents the trend of expansion at high temperatures. When the valve plug rotates, disassemble and remove the sediment on the outer surface of the valve plug. The metal lip edge provides automatic cleaning during rotation, suitable for sticky and prone to scaling conditions.

顶盖可调节螺栓 Adjustable Bolts on The Top Cover

阀盖的外部调节螺栓提供了快速而简单的调节，通过位于金属隔膜下方的金属止推垫圈施加平衡力，确保阀杆和密封件的压缩平衡。该机构提供了对大气的多重密封和双向在线密封。

The external adjustment bolt of the valve cover provides quick and simple adjustment, ensuring the compression balance of the valve stem and seal by applying a balancing force through a metal thrust washer located below the metal diaphragm. This institution provides multiple seals and bidirectional online seals for the atmosphere.

旋塞阀系列 PLUG VALVE SERIES

无润滑PTFE卡套No Lubrication of PTFE Sleeve

低摩擦系数的聚四氟乙烯是自润滑的，围绕着塞子可以快速方便地操作。省去了昂贵的润滑和维护。

The low friction coefficient PTFE is self-lubrication, surrounding the plug permits quick and easy operation. Costly lubrication and maintenance is eliminated.

可更换卡套Replaceable Sleeve

与其他阀门不同的是，密封套和密封垫在损坏时可以很容易地更换，而不是麻烦的阀门返回和密封部件的复杂匹配研磨或完全更换整个阀门，也就是说，套筒旋塞阀是一种经济的阀门类型，它可以有效地降低成本，缩短维护时间。

Differ from other valves, the sealing sleeve and sealing gasket can be easily replaced when damaged instead of troublesome valves return and complex match grinding of sealing parts or completely replace the whole valve, that is what we say, sleeved plug valve is economical valve type, which can effectively lower cost and shorten maintenance time

三重阀杆密封系统Threefold Stem Seal System

阀杆零泄漏密封是通过三重密封系统实现的。主密封由套筒提供，密封非常紧密，即使没有阀盖也无法观察到泄漏。二级和三级密封（顶部密封组件）由PTFE聚四氟乙烯三角环和隔膜提供。密封也非常紧密，没有泄漏。

The zero leakage stem sealing is achieved by threefold sealing system. The primary seal is provided by the sleeve, the sealing is so tight that no leakage can be observed even without a valve cover. The secondary and tertiary seal (top seal package) are provided by a PTFE Teflon delta ring and a diaphragm. The sealing is also so tight that no leakage.

防火设计Anti-fire design

采用柔性石墨制造的防火垫圈装在阀体中法兰的沟槽内，由阀盖压紧支撑环、密封隔片焊接在一起形成密封组，再压紧柔性石墨防火圈形成中部防火密封。金属密封调整垫压紧金属密封支撑环，内设柔性石墨锥度密封环，经调整螺栓同时压紧膜片形成阀杆防火密封副，若在火灾时PFA基复合物阀座和其它密封材料均被火毁，阀门仍保持阀杆及中部的密封性能，火灾安全阀门的旋塞上开设泄压孔，阀门受热时旋塞通道内的膨胀流体将由泄压孔释放，消除危害。

The fireproof gasket made of flexible graphite is installed in the groove of the flange in the valve body, and the valve cover is pressed to support the ring and the sealing spacer is welded together to form a sealing group. Then, the flexible graphite fireproof ring is pressed to form a middle fireproof seal. The metal sealing adjustment pad compresses the metal sealing support ring, which is equipped with a flexible graphite taper sealing ring. The adjusting bolt simultaneously presses the diaphragm to form a fireproof sealing pair for the valve stem. If the PFA based composite valve seat and other sealing materials are destroyed by fire during a fire, the valve still maintains the sealing performance of the valve stem and the middle. A pressure relief hole is opened on the plug of the fire safety valve. When the valve is heated, the expansion fluid in the plug channel will be released through the pressure relief hole, Eliminate hazards.

防静电结构Anti Static Device :

防静电装置在操作阀门时，阀塞与密封套之间的摩擦会在阀塞上产生静电。阀门上的防静电装置将产生火花塞上的电荷，以防止静电火花。特别是对于消防输气管道，必须进行防静电设计。另一方面，它会使可燃气体燃烧。该设计符合API67标准。

When the anti-static device operates the valve, the friction between the valve plug and the sealing sleeve will generate static electricity on the valve plug. The anti-static device on the valve will generate charges on the spark plug to prevent static sparks. Especially for fire and gas pipelines, anti-static design must be carried out. On the other hand, it can cause combustible gases to burn. This design complies with the API67 standard.

双压盖调节设计Double Pressure Caps Adjustment Design

一个压盖可调节阀杆密封填料的压缩，另一个压盖则可调节阀塞到套筒中的压力。这两种调节可以单独操作，确保了阀杆、阀塞的密封性，并将操作扭矩降至最低。

One gland can adjust the compression of the valve stem sealing packing while the other gland can adjust the pressure of the valve plug into the sleeve. These two adjustments can be operated separately to ensure the sealing of the valve stem and plug and to minimize the operating torque.

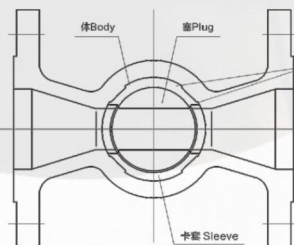

当塞子360度旋转时，密封唇可以清洁阀座以去除残留物，没有介质沉积确保不受到污染。
When plug rotation 360 degree, seals lips can clean the seat to remove residue, no medium deposit ensures no pollution.

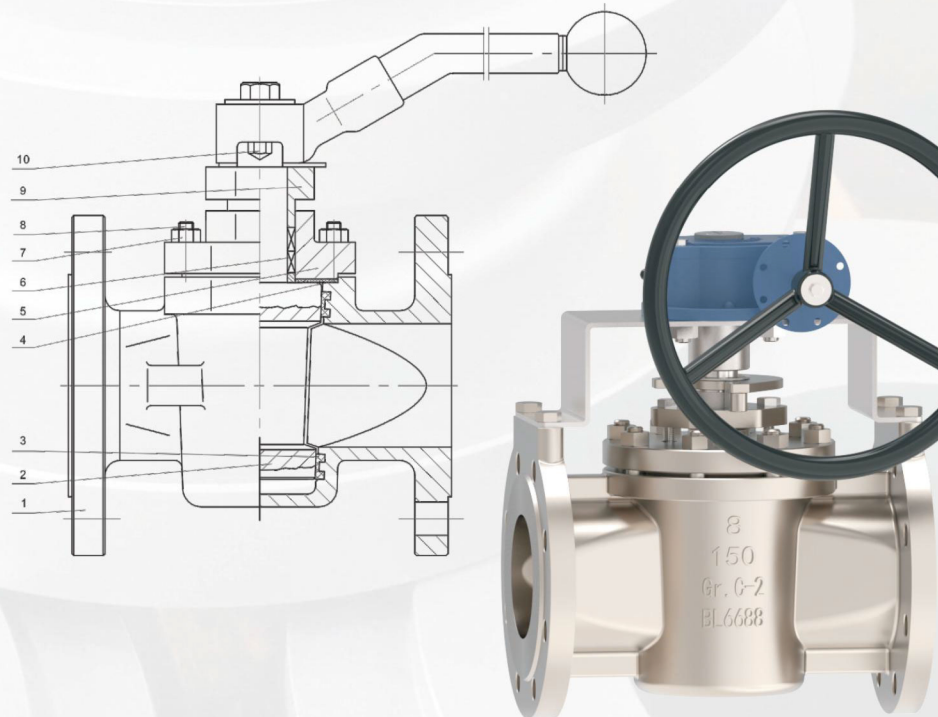

部件材料 Materials of Parts

序号 No	部件名称 Part Name	材料 Material		
		钛Titanium	哈氏合金Hastelloy C-4	锆Zirconium 705
1	阀体Body	B367 Gr. C-2	A494 CW2M	B752 705C
2	塞Plug	B367 Gr. C-2	A494 CW2M	B752 705C
3	阀座Seat	PPL	PPL	PPL
4	垫片Gasket	钛Titanium+石墨Graphite	哈氏合金Hastelloy+石墨Graphite	锆Zirconium+石墨Graphite
5	阀盖Bonnet	B367 Gr. C-2	A494 CW2M	B752 705C
6	填料Packing	PTFE+石墨Graphite	PTFE+石墨Graphite	PTFE+石墨Graphite
7	螺母Nut	A194 8M	A194 8M	A194 8M
8	螺栓Bolt	A193 B8M	A193 B8M	A193 B8M
9	压盖法兰Gland flange	A351 CF8M	A351 CF8M	A351 CF8M
10	调节螺栓Adjusting bolt	A193 B8M	A193 B8M	A193 B8M

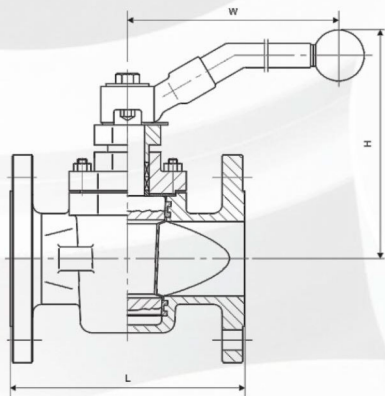

尺寸 Dimensions

Class 150																
口径 Size	mm	15	20	25	32	40	50	65	80	100	125	150	200	250	300	350
	in	1/2	3/4	1	1 1/4	1 1/2	2	2 1/2	3	4	5	6	8	10	12	14
L		108	117	127	140	165	178	190	203	229	254	267	292	330	356	381
H		110	115	115	135	140	150	165	180	380	460	520	580	620	680	760
W		175	175	175	220	280	305	350	405	300	300	320	320	350	380	450
重量Weight(kg)		8.5	9.5	10.5	12	14	18	22	26	40	60	70	130	219	381	570
Class 300																
口径 Size	mm	15	20	25	32	40	50	65	80	100	125	150	200	250	300	350
	in	1/2	3/4	1	1 1/4	1 1/2	2	2 1/2	3	4	5	6	8	10	12	14
L		140	152	165	178	190	216	241	283	305	381	403	419	457	502	762
H		110	115	115	135	140	150	165	180	380	460	502	580	620	680	760
W		175	175	175	220	280	305	350	405	300	300	320	320	350	380	450
重量Weight(kg)		9.5	10.5	12	14	16	20	24	29	53	75	85	185	230	390	550
Class 600																
口径 Size	mm	15	20	25	32	40	50	65	80	100	125	150	200	250	300	350
	in	1/2	3/4	1	1 1/4	1 1/2	2	2 1/2	3	4	5	6	8	10	12	14
L		165	190	216	229	241	292	330	356	432	508	559	660	787	838	889
H		110	115	115	135	140	150	165	180	380	460	520	580	620	680	760
W		175	175	175	220	280	305	350	405	300	300	320	320	350	380	450
重量Weight(kg)		11	13	17	20	23	27	31	36	72	98	141	245	330	515	710
Class 900																
口径 Size	mm	15	20	25	32	40	50	65	80	100						
	in	1/2	3/4	1	1 1/4	1 1/2	2	2 1/2	3	4						
L		229	229	254	279	305	368	419	381	457						
H		110	115	115	135	140	150	165	480	380						
W		175	175	175	220	280	305	350	405	300						
重量Weight(kg)		13	16	21	24	28	32	40	47	91						

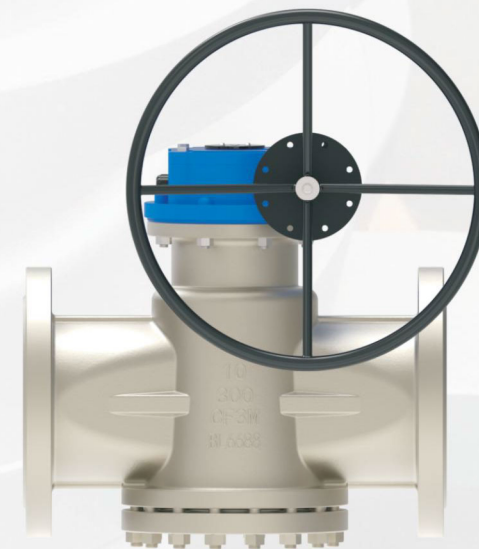
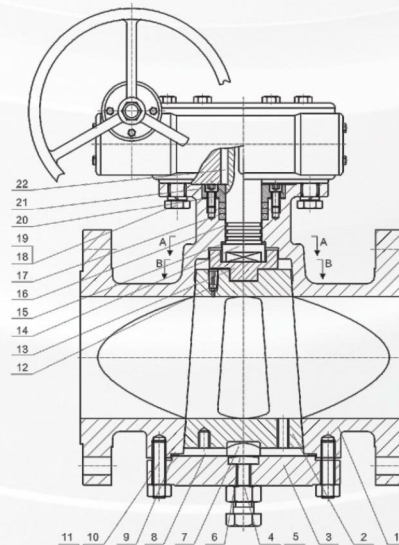

部件材料 Materials of Parts

序号 No	部件名称 Part Name	材料 Material		
		SS316	Inconel 600	Nickel 200
1	阀体Body	A351 CF3M	A494 CY40	A494 CZ100
2	塞Plug	A351 CF3M+Nitriding	A494 CY40	A494 CZ100
3	盖Cover	A351 CF3M	A494 CY40	A494 CZ100
4	螺母Nut	A194 8M	A194 8M	A194 8M
5	螺栓Blot	A193 B8M	A193 B8M	A193 B8M
6	调节块Adjustable block	A276 316	N06600	Nickel 200
7	调节块Adjustable block	A276 316	N06600	Nickel 200
8	金属隔膜Metal diaphragm	SS316	Inconel 600	Nickel 200
9	缠绕垫片Wrinkle gasket	SS316+石墨Graphite	Inconel 600+石墨Graphite	Nickel 200+石墨Graphite
10	螺母Nut	A194 8M	A194 8M	A194 8M
11	螺栓Blot	A193 B8M	A193 B8M	A193 B8M
12	止回阀Check valve	UCA	Inconel 600	Nickel 200
13	铰接Articulated joint	A276 316	Inconel 600	Nickel 200
14	阀杆Stem	A182 F316L	B564 N6600	B564 N02200
15	垫片Gasket	PTFE/石墨Graphite	PTFE+石墨Graphite	PTFE+石墨Graphite
16	O型圈O-ring	Viton	FKM	FKM
17	填料Packing	石墨Graphite	石墨Graphite	石墨Graphite
18	螺栓Blot	AISI 1035	AISI 1035	AISI 1035
19	弹簧垫圈Spring washer	AISI 1066	AISI 1066	AISI 1066
20	压盖Gland	A351 CF8M	A494 CY40	A494 CY40
21	螺栓Blot	A193 B8M	A193 B8M	A193 B8M
22	键Key	AISI 1045	AISI 1045	AISI 1045

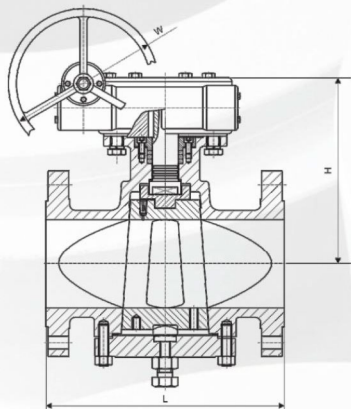

尺寸 Dimensions

		Class 150														
口径 Size	mm	15	20	25	32	40	50	65	80	100	125	150	200	250	300	350
	in	1/2	3/4	1	1 1/4	1 1/2	2	2 1/2	3	4	5	6	8	10	12	14
L		108	117	127	140	165	178	190	203	229	254	267	292	330	356	381
H		180	180	185	200	214	215	250	270	300	340	365	400	450	510	590
W		400	400	500	500	600	600	820	820	300	300	320	32	350	380	380
重量Weight(kg)		10	12	14	17	19	21	29	33	48	75	98	98	171	230	370
		Class 300														
口径 Size	mm	15	20	25	32	40	50	65	80	100	125	150	200	250	300	350
	in	1/2	3/4	1	1 1/4	1 1/2	2	2 1/2	3	4	5	6	8	10	12	14
L		140	152	165	178	190	216	241	283	305	381	403	419	457	502	762
H		180	180	185	200	210	215	250	270	300	340	365	400	450	510	590
W		400	400	500	600	600	820	1000	1000	300	400	320	320	350	380	380
重量Weight(kg)		12	14	16	19	21	24	31	36	61	83	130	190	255	380	560
		Class 600														
口径 Size	mm	15	20	25	32	40	50	65	80	100	125	150	200	250	300	350
	in	1/2	3/4	1	1 1/4	1 1/2	2	2 1/2	3	4	5	6	8	10	12	14
L		165	190	216	229	241	292	330	356	432	508	559	660	787	838	889
H		180	180	185	200	210	215	250	270	300	340	365	400	450	510	590
W		400	40	500	500	600	600	820	820	300	300	320	320	350	380	380
重量Weight(kg)		14	16	18	20	24	29	35	47	91	129	210	320	660	920	1250
		Class 900														
口径 Size	mm	15	20	25	32	40	50	65	80	100	125	150	200	250	300	350
	in	1/2	3/4	1	1 1/4	1 1/2	2	2 1/2	3	4	5	6	8	10	12	14
L		229	229	254	279	305	368	419	381	457	559	610	737	838	8965	1029
H		180	180	185	200	210	215	250	270	300	340	365	400	450	510	590
W		400	400	500	600	600	820	1000	1000	300	300	320	320	350	380	380
重量Weight(kg)		17	29	21	24	30	37	44	65	110	160	255	380	810	1050	1460

YOONAD VALVE (WUXI) CO.,LTD

友耐得阀门(无锡)有限公司

楔式闸阀 WEDGED GATE VALVES

自密封闸阀 PRESSURE SEALED GATE VALVES

口径 Size: 1/2" - 36" (15 - 900 mm)

压力 Pressure: ASME Class 150 - 2500LB

标准 Standard: API 600, API 6D, API 603, MSS SP-81

材质 Materials: B367 Gr. C-2, A494 CY40, B752 702C,

A890/A995 4A, 904L, A216 WCB, A351 CF8, A351.CF3M

