

YOONAD VALVE (WUXI) CO.,LTD

友耐得阀门(无锡)有限公司

铸钢止回阀 CASTING CHECK VALVES

自密封止回阀 PRESSURE SEALED CHECK VALVES

口径 Size: 2" - 30" (50 - 750 mm)

压力 Pressure: ASME Class 150 - 2500LB

标准 Standard: API 600, API 603, BS1873

材质 Materials: B367 Gr. C-2, A494 CY40, B752

702C, A890/A995 4A, 904L, A216 WCB, A351 CF8,

A351.CF3M



铸钢止回阀 CAST STEEL CHECK VALVE

yoonad®

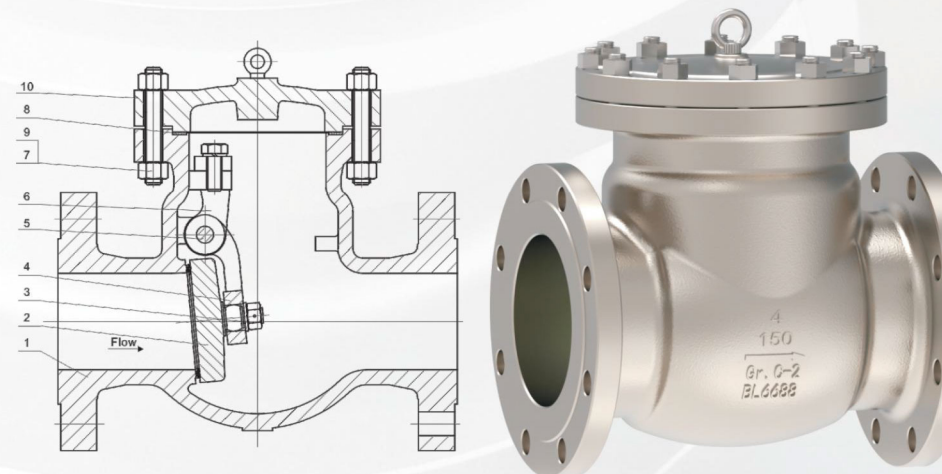

部件材料 Materials of Parts

序号 No	部件名称 Part Name	材料 Material		
		钛 Titanium	Incolloy 800	254SMO
1	阀体 Body	B367 Gr. C-2	A351 CT15C	A351 CK3MCuN
2	阀瓣 Disc	B367 Gr. C-2	A351 CT15C	A351 CK3MCuN
3	螺母 Nut	A194 8M	A194 8M	A194 8M
4	铰合部 Hinge	B367 Gr. C-2	A351 CT15C	A351 CK3MCuN
5	销 Pin	B348 Gr.2	B408 N08800	A182 F44
6	支架 Yoke	B367 Gr. C-2	A351 CT15C	A351 CT15C
7	螺母 Nut	A194 8M	A194 8M	A194 8M
8	螺栓 Bolt	A193 B8M	A193 B8M	A193 B8M
9	垫片 Gasket	钛 Titanium+石墨 Graphite	Incolloy+石墨 Graphite	254SMO+石墨 Graphite
10	阀盖 Bonnet	B367 Gr. C-2	A351 CT15C	A351 CK3MCuN

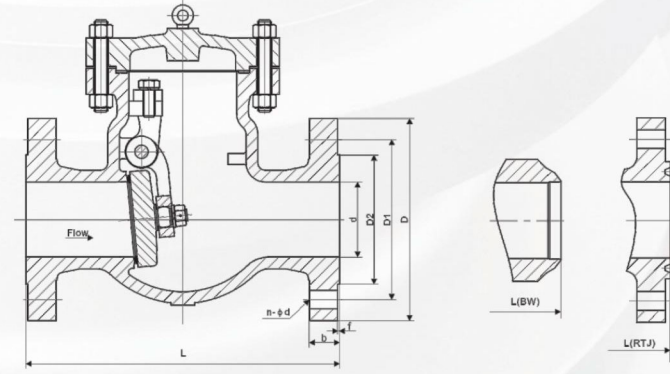
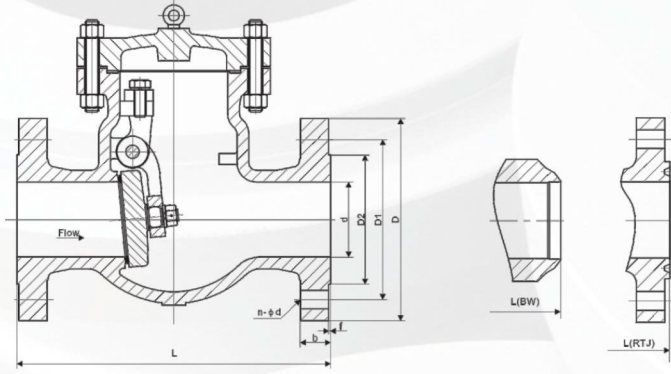

尺寸 Dimensions

口径 Size	尺寸 Dimensions(mm)											
	L			d	H	重量 Weight (kg)	L			d	H	重量 Weight (kg)
	RF	RTJ	BW				RF	RTJ	BW			
	Class 150						Class 300					
2	203	216	203	51	132	15	267	283	267	51	144	20
2 1/2	216	229	216	64	147	20	292	308	292	64	169	35
3	241	254	241	76	176	27	318	333	318	76	210	40
4	292	305	292	102	198	45	356	371	356	102	260	61
5	330	343	330	127	255	58	400	416	400	127	295	80
6	356	368	356	152	320	69	445	460	445	152	326	130
8	495	508	495	203	380	131	533	549	533	203	380	190
10	622	635	622	254	440	219	622	638	622	254	440	296
12	699	711	699	305	480	321	711	727	711	305	520	450
14	787	800	787	337	530	380	838	854	838	337	540	640
16	864	876	864	387	580	560	864	879	864	387	588	850
18	978	991	978	438	618	630	978	994	978	438	670	1030
20	978	991	978	489	657	770	1016	1035	1016	489	720	1330
24	1295	1308	1295	591	760	960	1346	1368	1346	591	850	1950
26	1295	-	1295	633	840	1250	1346	1372	1346	633	920	2300
28	1448	-	1448	684	920	1580	1499	1524	1499	684	1150	2600
30	1524	-	1524	735	980	1950	1594	1619	1594	735	1260	3200

尺寸 Dimensions

口径 Size	尺寸 Dimensions(mm)											
	L			d	H	重量 Weight (kg)	L			d	H	重量 Weight (kg)
	RF	RTJ	BW				RF	RTJ	BW			
	Class 600						Class 900					
2	292	295	292	51	170	28	368	371	368	47	200	48
2 1/2	330	333	330	64	178	40	419	422	419	57	220	75
3	356	359	356	76	246	68	381	384	381	73	280	95
4	432	435	432	102	290	117	457	460	457	98	320	135
5	508	511	508	127	320	155	559	562	559	121	360	200
6	559	562	559	152	360	192	610	613	610	146	400	264
8	660	664	660	200	430	340	737	740	737	190	480	424
10	787	791	787	248	502	515	838	841	838	234	560	730
12	838	841	838	2978	554	750	965	968	965	282	632	1070
14	889	892	889	327	595	890	1029	1038	1029	311	680	1180
16	991	994	991	375	680	1303	1130	1140	1130	354	780	1790
18	1092	1095	1092	419	778	1800	1219	1232	1219	400	880	2560
20	1194	1200	1194	464	970	2150	1321	1334	1321	444	1050	3080
24	1397	1407	1397	559	1100	3200	1549	1568	1549	533	1200	14600

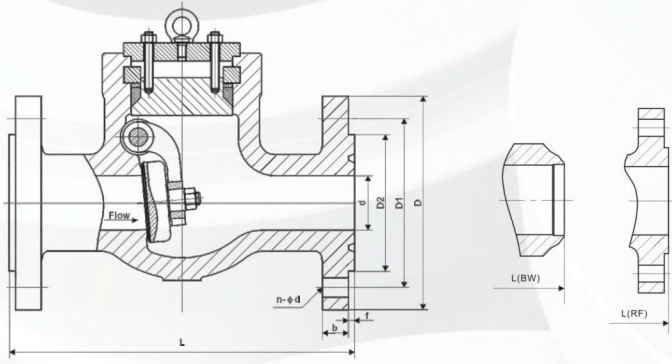

尺寸 Dimensions

口径 Size	尺寸 Dimensions(mm)			d	H	重量 Weight(kg)
	RF	RTJ	BW			
Class 1500						
2	368	371	368	47	210	48
2 1/2	419	422	419	57	240	75
3	470	473	470	70	303	120
4	546	549	546	92	340	180
5	673	676	673	111	380	294
6	705	711	705	136	430	385
8	832	8411	832	174	500	634
10	991	1000	991	222	590	1140
12	1130	1146	1130	263	660	1650
14	1257	1276	1257	289	710	2000
16	1384	1407	1384	330	820	2700

尺寸 Dimensions

口径 Size	尺寸 Dimensions(mm)			d	H	重量 Weight(kg)
	RF	RTJ	BW			
Class 2500						
2	451	454	451	35	230	68
2 1/2	508	514	508	47	260	100
3	578	584	578	57	330	165
4	673	683	673	73	370	260
5	794	807	794	92	410	440
6	914	927	914	111	460	580
8	1022	1038	1022	146	530	970
10	1270	1292	1270	184	620	1700
12	1422	1445	1422	219	690	2600
14	-	-	-	-	-	-
16	-	-	-	-	-	-

可用材料表 Material

钛以及钛合金 Titanium & Titanium Alloy				
材料 Material	棒材 Bars	锻造 Forging	铸造 Casting	
钛 Titanium	Titanium TA1	GB/T2965 TA1	GB/T25137 F-1	GB/T6614 ZTA1
	Titanium TA2	GB/T2965 TA2	GB/T25137 F-2	GB/T6614 ZTA2
	Titanium Gr.2	B348 Gr.2	B381 Gr. F-2	B367 Gr. C-2
	Titanium Gr.3	B348 Gr.3	B381 Gr. F-3	B367 Gr. C-3
	Titanium Gr.5	B348 Gr.5	B381 Gr. F-5	B367 Gr. C-5
钛合金 Titanium Alloy	Titanium Gr.6	B348 Gr.6	B381 Gr. F-6	B367 Gr. C-6
	Titanium Gr.7	B348 Gr.7	B381 Gr. F-7	B367 Gr. C-7
	Titanium Gr.12	B348 Gr.12	B381 Gr. F-12	B367 Gr. C-12
	Titanium Gr.TC4	GB/T2965 TC4	GB/T2965 TC4	GB/T6614 ZTC4
	Titanium Gr.TA9	GB/T2965 TA9	GB/T2965 TA9	
	Titanium Gr.TA10	GB/T2965 TA10	GB/T2965 TA10	
镍以及镍基合金 Nickel & Nickel Base Alloy				
镍 Nickel	Nickel200	B160 N04400	B564 N02200	A494 CZ100
	Nickel201	B160 N02201	B564 N02201	
	Monel 400	B164 N04400	B564 N04400	A494 M35-1/M35-C
	Monel K500	B865 N05500	B865 N05500	
	Inconel 600	B166 N06600	B564 N06600	A494 CY40
镍基合金 Nickel Base Alloy	Inconel 625	B446 N06625	B564 N06625	A494 CW6MC
	Incoloy 800	B408 N08800	B564 N08800	A351 CT15C
	Incoloy 800H	B408 N08810	B564 N08810	
	Incoloy 825	B425 N08825	B564 N08825	A494 CU5MCuC
	Hastelloy B	B335 N10001	B335 N10001	A494 N12MV
	Hastelloy B-2	B335 N10665	B462 N10665	A494 N7M
	Hastelloy B-3	B335 N10675	B564 N10675	
	Hastelloy C276	B574 N10276	B564 N10276	A494 CW12MW / CW6M
	Hastelloy C-22	B574 N06022	B564 N06022	A494 CX2MW
	Hastelloy C-4	B574 N06455	B574 N06455	A494 CW2M
	Hastelloy G	B581 N06007	B462 N06007	
	Hastelloy G30	B581 N06030	B462 N06030	
锆 Zirconium	Zirconium 702	B550 R60702	A493 R60702	B752 702C
	Zirconium 705	B550 R60705	A493 R60705	B752 705C
双相钢以及超级双相钢 Duplex & Super Duplex				
双相钢 Duplex	Duplex S32205	A276 S32205	A182 F60	A890/A995 4A(CD3MN)
	Duplex S31803	A276 S31803	A182 F51(2205)	A890/A995 4A(CD3MN)
超级双相钢 Super Duplex	Super-Duplex S32750	A276 S32750	A182 F53(2507)	A890/A995 5A(CE3MN)
	Super-Duplex S32760	A276 S32760	A182 F55	A890/A995 6A(CD3MWCuN)
铜合金 Copper Alloy				
铜合金 Copper Alloy	Ni-Al-Br			B148 C95800
	Ni-Al-Br			B148 C95500
	Ni-Al-Br			B148 C95400
超级奥氏体不锈钢 Super Austenitic Stainless Steel				
超级奥氏体不锈钢 Super Austenitic Stainless Steel	904L	A182 F904L	A182 F904L	904L
	254SMO	A182 F44	A182 F44	A351 CK3MCuN
	AL-6XN	B462 N08367	B462 N08367	A351 CN3MN
	Alloy20	B462 N08020	B462 N08020	A351 CN7M
奥氏体不锈钢 Austenitic Stainless Steel				
奥氏体不锈钢 Austenitic Stainless Steel	304	A276 304	A182 F304	A351 CF8
	304L	A276 304L	A182 F304L	A351 CF3
	316	A276 316	A182 F316	A351 CF8M
	316L	A276 316L	A182 F316L	A351 CF3M
	316Ti	A276 316Ti	A182 F316Ti	
	317	A276 317	A182 F317	A351 CG8M
	317L	A276 317L	A182 F317L	A351 CG3M
	347	A276 347	A182 F347	A351 CF8C
	310	A276 310	A182 F310	A351 CK20